

PHILIPS

Image Guided Therapy
Mobile C-arm System

7000

Zenition 70



Philips Image Guided Therapy Mobile C-arm System 7000 – Zenition 70

Specifications

Experience exceptional clarity and flexibility for performing a wide variety of cases with the Philips Image Guided Therapy Mobile C-arm System 7000 – Zenition 70 - our fourth-generation Flat Detector systems. With Zenition 70, you get a harmonized range of systems designed to reduce operational costs, simplify use and streamline fleet management. Experience the same intuitive control and handling on all systems. Every Zenition 70 system shares a standard Windows® platform and is ready to embrace new clinical applications and service and support technologies as they evolve. The Technology Maximizer program helps you manage upgrade costs for years to come.





Contents

1 - Flat Detector	4
2 - Geometry	5
3 - Imaging	6
4 - X-ray generation	9
5 - Workflow	12
6 - Clinical extensions	15
7 - System overview	16
8 - Dimensions	18
9 - Options	21
10 - Service	23

1 - Flat Detector



Zenith 70 with 30 x 30 cm flat detector

Zenith 70 with 26 x 26 cm flat detector

Zenith 70 with 21 x 21 cm flat detector

Specifications	FD 30 x 30 cm	FD 26 x 26 cm	FD 21 x 21 cm
Flat detector type	Trixell amorphous silicon detector	Trixell amorphous silicon detector	Trixell amorphous silicon detector
Scintillator	Cesium Iodide	Cesium Iodide	Cesium Iodide
Matrix	1956 x 1956 pixels	1560 x 1424 pixels	1344 x 1344 pixels
Field of View	30.12 x 30.12 cm (11.86" x 11.86") Zoom: 30.12 / 22.17 / 15.4 cm (11.86" / 8.73" / 6.06")	26.2 x 26.2 cm (10.3" x 10.3") Zoom: 26.2 / 18.4 / 13.3 cm (10.3" / 7.2" / 5.2")	20.7 x 20.7 cm (8.15" x 8.15") Zoom: 20.7 / 15.4 / 11.0 cm (8.15" / 6.06" / 4.33")
Pixel Pitch	154 µm	184 µm	154 µm
Dynamic range	94 dB	96 dB	96 dB
A/D conversion	16 bit	16 bit	16 bit
DQE (@ 0 lp/mm)	0.77	0.70	0.77
MTF (@ 1 lp/mm)	0.6	0.59	0.59
Spatial resolution measured on grid surface, no filters in beam	OV: 2.2 lp/mm Z1 : 2.8 lp/mm Z2 : 3.7 lp/mm	OV: 2.5 lp/mm Z1: 3.4 lp/mm Z2: 3.4 lp/mm	OV: 2.8lp/mm Z1: 3.7 lp/mm Z2: 4.0 lp/mm
Nyquist frequency	3.25 lp/mm	2.70 lp/mm	3.25 lp/mm
Calibration	Auto calibration after 30 seconds during idle state	Auto calibration after 30 seconds during idle state	Auto calibration after 30 seconds during idle state
Grid Lines / cm	74	70	74
Grid material	Focused Grid, Carbon fibre cover	Focused Grid, Carbon fibre cover	Focused Grid, Carbon fibre cover
Grid Ratio	14:01	13:1	14:1

2 - Geometry

2.1 C-arm stand specifications

Angulation	140° rotation (+90° / -50°) offers a maximum of projection flexibility
Motorized height movement Speed	490 mm / 19.3" typical: up ~1.8 cm/s, down ~2.4 cm/s
Longitudinal movement	200 mm / 7.9"
Panning movement (swivel)	± 10°
Rotation	± 200° (standard) ± 205° (max.)
Lowest lateral position	1027 mm (C-arc under table) 837 mm (C-arc over table)
Source to image distance (SID)	993 mm / 39.1"
Free space in C-arm	770 mm / 30.4"
C-arm depth	730 mm / 29"
Parallel movement	Dedicated parallel movement with rear-wheel steering, for easy positioning along operating table
C-arm stand length	2060 mm
Weight	FD 30 x 30 cm: 350 kg (max), FD 26 x 26 cm: 336 kg, FD 21 x 21 cm: 332 kg
C-arm stand width	815 mm
C-arm stand height	1800 mm
Brakes on all movements	Yes, manual
Steering	Rear wheels
Cable deflectors	Yes

2.2. Mobile View Station specifications

Depth	701 mm
Width	702 mm (monitors folded) 943 mm (monitors unfolded)
Height	1850 mm
Weight (including options)	140 kg
Monitor rotation	180°
Monitor height movement	230 mm



3 - Imaging

Specifications

SmartVision

- Flat Detector active matrix: FD30 x 30 (1956 x 1956 pixels), FD 26 x 26 (1560 x 1424 pixels), FD 21 x 21 (1344 x 1344) pixels. Captures small details of region of interest
- Unique BodySmart software allows free positioning of the anatomy, even at the edge of the image detector. It automatically detects anatomy and adjusts parameters to produce high quality images
- Contrast and brightness can be adjusted automatically in real time or manually
- Our fully automatic MetalSmart feature excludes metal artifacts caused by metal implants to provide higher image quality and efficient dose control for orthopedic and other procedures, compared to systems without metal exclusion
- Philips premium imaging technologies correct for patient or accidental table motion, automatically and in real-time on live images; reduce noise and artifacts, also on moving structures and objects; and enhance images and sharpen edges



Specifications

DoseWise

- Imaging modes:
 - Fluoro modes ranging from Low X-ray dose to High Level, enabling dose savings when desired or enhanced image quality when necessary
 - Three different pulse rates for fluoro modes; the lower pulse rate can help to manage X-ray dose
 - Collimation:
 - Graphical shutter and iris and image orientation on Last Image Hold image on C-arm stand tablet-like UI without applying radiation
 - Real lead asymmetrical shutters
 - Independent shutter positioning
 - Automatic Electronic Blanking following the lead shutters and iris to enhance image quality
 - Automatic Shutter Positioning (ASP) sets shutters to the anatomy of interest for excellent image quality at the touch of a button
 - The integrated laser lets staff position the C-arm without using radiation
 - Several features contribute to increased dose awareness, including dose reporting, dose display, and an alert when exceeding a pre-defined procedure dose level
-

Acquisition settings

Preset acquisition settings apply dedicated fluoroscopy settings to obtain superb image quality for the anatomy of interest without applying more X-ray dose than necessary. Within each program there are different X-ray modes available (depending on anatomy of interest):

- Low Dose Fluoroscopy
- Normal Dose Fluoroscopy
- Medium Dose Fluoroscopy
- High Dose Fluoroscopy
- Exposure run to produce high quality images
- Single shot exposure, for extra-sharp, single snapshot images
- Hiding choices on the UI
- Auto Contrast Brightness (ACB) on/off settings
- Subtraction
- Trace

Blur reduction and noise reduction buttons to further adjust the level of temporal noise reduction to the amount of movement in the region of interest

Removable grid

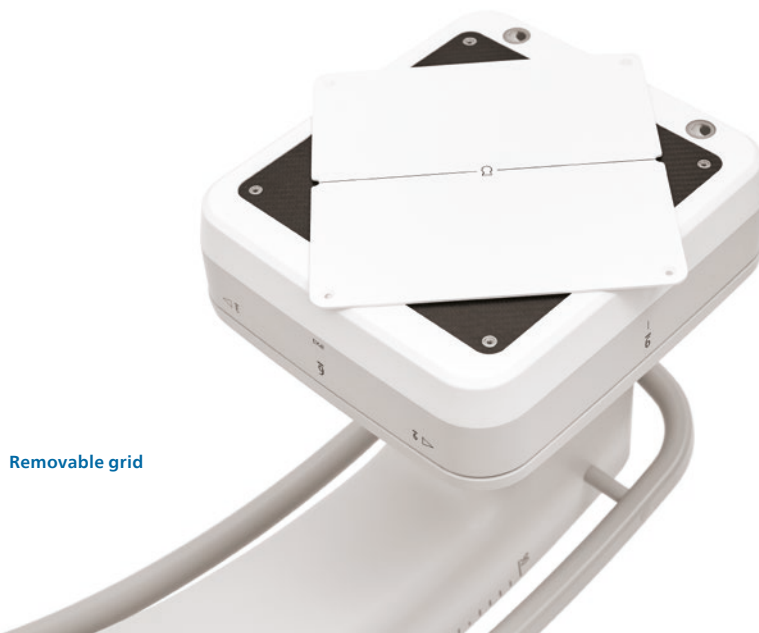

Specifications

Real time processing functions

Feature	<ul style="list-style-type: none">• Feed-forward gain control• White compression• Adaptive temporal recursive noise reduction• Adaptive multiresolution brightness / contrast / edge enhancement / Spatial noise reduction• Blanking• Video invert• Digital image rotation• Mirroring• Flipping• Manual / auto contrast / brightness
----------------	---

Post processing functions

Feature	<ul style="list-style-type: none">• 360° digital rotation mirror left / right and up / down without radiation• Contrast and Brightness• Annotation (for a single image or all images in an examination)• Video invert (negative)• Zoom and roam (factor 2x real-time magnification, freely movable to any section of an image)• Measurement (to precisely quantify lengths and angles in images)• Electronic shutters (to block out over exposed areas outside the region of interest)
----------------	--

Mobile view station monitors

Resolution	1280 x 1024 pixels
Maximum light output	650 cd/m2
Minimal contrast ratio	1/400
Contrast ratio	>700:1 (high brightness)
Viewing angle	170° in horizontal and vertical direction
Tablet-like UI	Offers easy access to post-processing of acquired images, patient demographics as well as patient administration and data export (live monitor)
Monitors	Two 19" High Brightness Color LCD monitors for diagnostic image quality display. Monitor LUT: <ul style="list-style-type: none">• DICOM GSDF compliant

4 - X-ray generation

Specifications

X-ray generator	Zenition 70 FD uses a monoblock architecture with the high tension transformer in the X-ray tank. With the monoblock there is no need to transmit pulses over high voltage cables, which can result in a ramping up and ramping down effect, due to the electrical impedance of the cables. Because the monoblock generator operates at high frequencies (80 kHz), it produces sharp pulses, which results in fewer motion artifacts in the image. This also allows less soft radiation to be used and produces less heat.
X-ray tube	Zenition 70 systems have a rotating anode and high power generator with excellent heat management to perform the most demanding interventional procedures.
Tube type	Rotating anode X-ray tube
Nominal x-ray tube voltage	120 kV
Nominal focal spot values	0.3 and 0.6 mm
Maximum anode heat content	315 kHU = 225kJ
Max. uninterrupted fluoro time	10 minutes legal block
Maximum continuous anode heat dissipation	550 W
Max anode heat dissipation:	54 kJ/min = 75.6 kHU/min = 900 W
Anode rotating speed	3000 rpm
Anode target angle	10°
Anode material	RT-TZM (Rhenium-Tungsten-Titanium-Zirconium-Molybdenum)
Maximum housing heat content	1350 kJ = 1890 kHU
Maximum housing heat dissipation	192 W = 11.5kJ/min = 16.1kHU/min
Maximum continuous housing heat dissipation	120 W = 7.2kJ/min = 10.1 kHU/min
Cooling method	Active oil-circulation cooling
Inherent filter	0.75 mm Al eq at 75 kV
Integrated beam filter	1.0 mm Al. equivalent + 0.1 mm Cu
Total beam filtration	4.73 mm Al. equivalent
Max. generator output	15 kW

Specifications

Operating values with Pulsed Fluoroscopy

kV range	40-120 kV
mA peak range	0.5-60 mA
Pulse width	5.333 ms – 85.333 ms
Pulse rate	1 - 2 - 4 - 7.5 - 15 – optional 30

Operating values with Exposure runs

kV range	40-120 kV
mA peak range	0.625 to 60.0 mA
Pulse width	7.407 ms to 71.111 ms
Pulse rate	4 - 7.5 - 15 – optional 1-2-30

Operating values with Single shot exposure (snapshot)

kV range	40-120 kV
mA peak range	2.5 to 60.0 mA (normal) 5.2 to 125 mA (high power) (optional)
Time range	100 and 165 ms (normal) 100 ms (high power)
X-ray collimation	Zenition 70 makes collimation easy. Its full lead shutters can be rotated and moved independently, and the unique Philips Automatic Shutter Positioning (ASP) feature automatically positions shutters for excellent image quality at the touch of a button. You can position shutters or adjust the iris on the last X-ray image (Last Image Hold on stand UI), enabling the shutters or iris to be positioned without the need for live fluoroscopy.

Specifications

Shutters	Two independent lead shutters with steel wedge: shutters can be coupled for rotation and translation, or moved individually for asymmetric collimation
Automatic shutter positioning	Automatic shutter placement based on image content
Shutter material	3 mm Pb
Rotation of shutter	360°
Wedge material	0.2 to 2.5 mm stainless steel
Adjustment of shutter and iris	Stepless
Iris material	Lead with 5% antimony: Pb (Sb5%)
Iris diameter (at detector)	FD 30: < 50-400 mm, FD 26: <50-372 mm, FD 21: <50-290 mm
Position indication	On screen and also on last image hold without radiation on Stand UI



Zenition 70 with 30 x 30 cm flat detector



Zenition 70 with 26 x 26 cm flat detector



Zenition 70 with 21 x 21 cm flat detector

5 - Workflow

Specifications

Unify workflow

- Tablet-like UI
- ClearGuide and color coding
- Position memory (option)

Unify workflow brings intuitive control and handling to your system to reduce training and enhance teamwork.

Physicians and operators experience a whole new level of simplicity with our tablet-like user interface on the C-arm and intelligent workflow. Now you can just touch the screen with a finger to drag the shutters and iris into position on Last Image Hold. At each step you only see the features you need, making it easy to find the right selections.

Our unique ClearGuide in combination with color coding on the C-arm speeds up positioning. ClearGuide provides a uniform reference for the operator and physician to use during positioning. A set of numbers (3, 6, 9, 12) on the Detector corresponds to the same numbers displayed on the clinical image. The physician can say 'Rotate orange towards 3' and the operator knows exactly what to do. The numbers always match up, even if the image is rotated, flipped, or mirrored.

Returning the C-arm to the exact position to check placement of a pedicle screw during spinal surgery can require additional scout images without extra positioning guidance. With Position Memory, you can store a previous position and recall it when needed to speed up re-positioning.

Mobile View Station

The compact Mobile View Station fits perfectly in the surgical workflow. Its intelligent design provides the user with easy system set-up, enhanced viewing capabilities and easy transportation. Its unique design also makes it easy to clean. All system controls are at your fingertips on the live monitor of the Mobile View Station. With this tablet-like UI, you can intuitively set up an exam, post-process images, or export a case to PACS. The operator can easily see the clinical image on this 15" stand UI screen without obstructing the view of the physician. Because we use advanced infra-red technology, the touchscreen monitor delivers the same image quality as non-touchscreen monitors.

Super thin flat detector

The super thin Flat Detector frees up valuable workspace around the patient during challenging procedures. It gives you more room to see your patient, to see team members, and to coordinate tasks.

Connectivity

- The Wireless Data Transfer option allows users to connect to the RIS/HIS to send and retrieve images or other relevant data wirelessly and reduce the amount of cable clutter in the OR
- Optional Digital Video out to display live and reference images on additional monitors (e.g. ceiling mounted) without a loss of resolution
- Optional Video in allows you to conveniently display external video signals like endoscopy or ultrasound on the right C-arm monitor, so all the information needed is in one view
- Optional USB storage provides a convenient way to store and images for use in reports or presentations



ClearGuide

Specifications

Integrated laser	An integrated laser in the Flat Detector housing, can be activated and deactivated at the touch of a button, enabling accurate positioning of the C-arm without radiation. 635 nm Maximum output < 10 m W Laser class 1M (IEC)
DICOM	DICOM is seamlessly integrated into the system for digital image to DICOM translation. A highly intuitive user interface simplifies use. <ul style="list-style-type: none"> • DICOM print (optional) • DICOM store (optional) • Modality Worklist Management (MWL) • Modality Performed Procedure Step (MPPS) • Storage Commit (optional) • DICOM Storage to DVD or USB memory (optional) • DICOM query/retrieve (optional) • DICOM Radiation Dose Structured Reports DICOM image formats: <ul style="list-style-type: none"> • Secondary Capture (SC) with/without text • Angiography (XA - multi frame) • Patient dose report
Integrated Healthcare Enterprise (IHE)	Zenition 70 is compliant with the IHE Scheduled Workflow Integration Profile as an Acquisition Modality Actor. For an optimal viewing angle, the LCD monitors can be rotated 180° and adjusted in height (230 mm/9")
Digital video out	2 DVI connectors live and reference monitor
Video in (optional)	S-Video, DVI (digital and analog), SDI
USB storage (optional)	PNG, MP4, BMP
IP addressing	Static IP, DHCP
Wireless standards supported	IEEE 802.11a / b / g / n / ac (2.4GHz and 5 GHz band) FIPS 140-2:compliant
Number of antennas	2 (embedded within the system, not visible)
User configurable SSID support	Up to 16 SSIDs, each with a unique MAC address and configurable SSID Broadcast
Authentication protocols	PSK, IEEE 802.1x EAP-TLS and PEAP AES, TKIP and WEP encryption FIPS 140-2 compliant
Security	Whitelisting to prevent malware
External room X-ray indication	Yes (optional)

PC Hardware details

# of USB ports	2 USB 2.0 and 1 High speed USB 3.0 port
Storage	Up to 140,000 images
DICOM STORE (DVD/USB) and Retrieve (USB/DVD/PACS)	Yes
Embedded MMV	Image Viewer (optional)
Service Tools (PSC, Remote, LOTS)	On system service tool (Philips Support Connect) Remote Service Remote Assistance (Look Over The Shoulder, LOTS)
Boot up time	< 77 seconds
Operating system	Windows® 10 LTSC 2019
• Processor speed	Intel Core™ i7-4790S (4 GHz)
• RAM	8GB: 2x DDR3 1600 MHz 4GB SO-DIMM
• Storage type	2x 500GB HDD
Image processing bits	FD subsystem: 16 bits, system image processing: 14 bits
Storage capacity in GB	2 x 500GB HDD of which ~300GB or 140,000 images for image storage
Storage image matrix	1 k x 1 k
Storage image bits	14 bit image data + 1 bit measuring field



6 - Clinical extensions

Specifications

Outlining	The outlining tool allows users to draw an outline (in 5 different colors, 1 color at a time) digitally on an image on the tablet-like UI using finger or your externally connected mouse, for example, to mark a bifurcation or side branches on live fluoroscopy images. Drawings can be switched/toggled on and off. The undo button corrects mistakes and the delete function gets rid of the drawing with the touch of a button.
Pain management extension	The Pain management extension offers digital subtraction functionality to enable enhanced visualization of contrast medium injections. Pain interventionalists can work with confidence to avoid potentially dangerous intravascular injections when using digital subtraction to enhance visualization of contrast distribution.
Cardiac extension	This combination of dedicated cardiac exam types, high pulse rates and expanded image memory of 140,000 images is the ideal package for cardiac interventions. The cardiac extension includes dedicated anatomical programmed fluoroscopy parameters for electrophysiology procedures, pacemaker placements, and cardiac surgery. With motion-stopping pulses of up to 30 pulses per second and 60 mA, the Zenition 70 captures sharp images of fast moving anatomy in the region of interest. Larger memory (140,000 images) provides capacity to record long cases at high frame rates.
Vascular extension	The vascular extension offers you the full support for vascular cases, providing an extensive range of vascular imaging tools. Most vascular functions can be controlled by handheld remote or at the user interface on the Mobile View Station. Image memory of 140,000 images available along with footswitch.
Vascular Processing	<ul style="list-style-type: none">• Subtracted fluoroscopy mode displays images in subtracted mode• Trace mode shows in real time the maximum opacification of the vessels (iodine and CO₂)• Roadmap images support catheter guidance• Remask lets you reselect the most suitable image in your run as a mask image for contrast runs• Smart Mask manages dose and contrast medium usage by re-using previously acquired images for roadmapping• Landmarking provides a non-subtracted background image for anatomical reference• Real time pixel shift compensates for movement artifacts• Subtraction on/off simplifies the orientation for subtracted images during roadmap procedures (controlled by remote control or User Interface on the Mobile View Station)• View Trace creates a trace image in post-processing (Iodine + CO₂)• CO₂ mode for subtraction, trace white and roadmap with Smart Mask and View Trace
Cardiovascular extension	The cardiovascular extension provides high quality fluoroscopy, subtraction runs, and roadmap guidance to support challenging cardiac and vascular procedures. Vascular processing features include subtracted fluoroscopy mode, trace mode to show the maximum opacification of vessels in real time, and real-time pixel shift to compensate for movement artifacts. Extra support for cardiac examinations is provided with dedicated anatomically programmed fluoroscopy parameters for electrophysiology procedures, pacemaker placements, and cardiac surgery. With motion-stopping pulses of up to 30 pulses per second and 60 mA, the Zenition 70 captures high quality images of fast moving anatomy in the region of interest.

7 - System overview

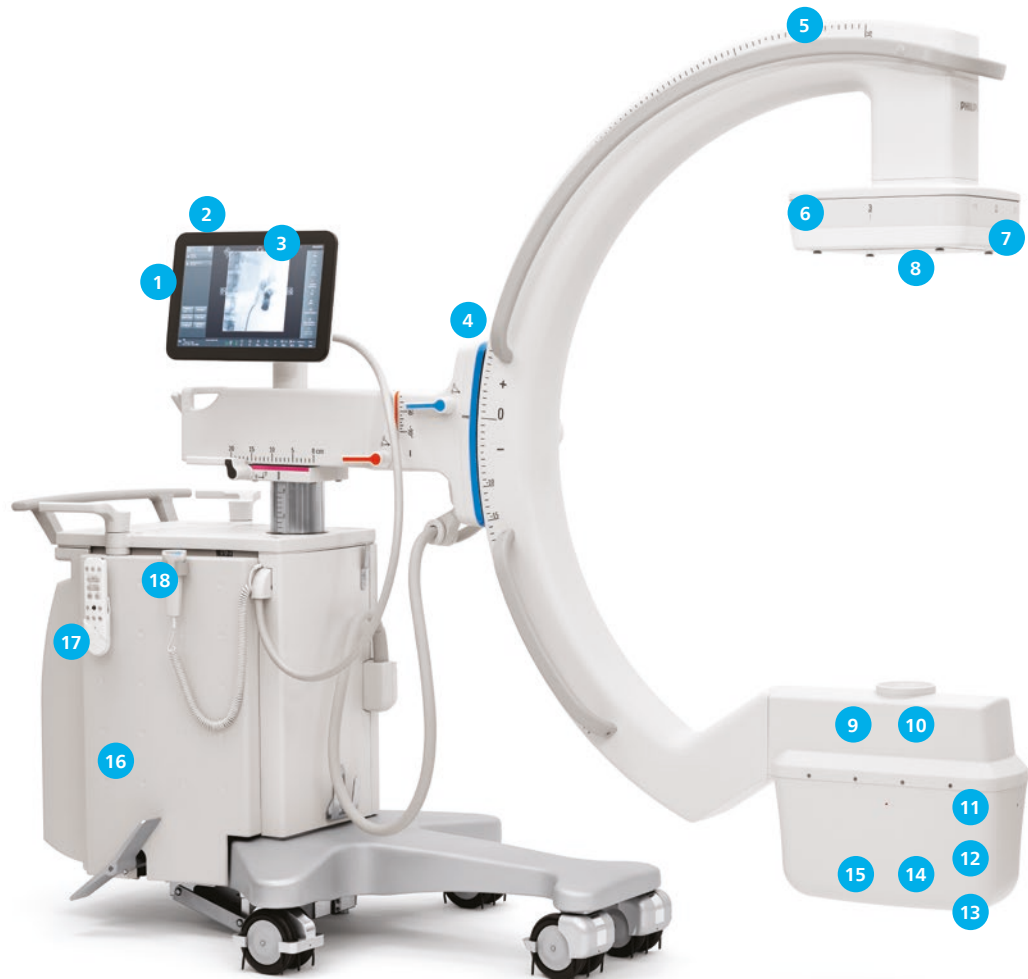

- 1 Tablet-like UI (Unify Workflow)
- 2 Application specific protocols and customizable presets
- 3 Adjust shutter and image orientation while on LIH
- 4 Color coding (Unify Workflow)
- 5 Fully Counterbalanced C-arc
- 6 3 Flat detector sizes (30 x 30 cm, 26 x 26 cm, 21 x 21 cm)
- 7 ClearGuide (Unify Workflow)
- 8 Removable X-ray grid
- 9 Unique asymmetric shutters
- 10 A smart new way of filtering
- 11 BodySmart
- 12 MetalSmart
- 13 15kW system
- 14 Compact X-ray tank
- 15 Monoblock design
- 16 Technology Maximizer
- 17 Remote control
- 18 Point and Shoot design



- 19 Outlining
- 20 High Speed wireless data transfer / Wireless data handling
- 21 Image Viewer/MMV
- 22 Lightweight MVS
- 23 Advanced Image Processing algorithms/radiation management features
- 24 80 seconds boot-up
- 25 Remote Support + Philips Support Connect tool
- 26 Windows® Platform
- 27 Advances Connectivity and interoperability tool
- 28 External Video In

8 - Dimensions

Specifications

C-arm stand

FD 30 x 30 cm

- Flat Detector:
height x width x depth:
12.3 cm x 40.2 cm x 43.4 cm
- Tube Tank:
height x width x depth:
39.4 cm x 18.7 cm x 46.7 cm
- SID (focus to II surface distance): 993 mm
- Focus to end of collimator assembly distance: 14.8 cm (source to diaphragm distance); 20.3 cm (source to IEC 20 cm spacer cover); 30.3 cm (source to HHS 30 cm spacer cover)

FD 26 x 26 cm

- Flat Detector:
height x width x depth:
7.8 cm x 35.9 cm x 44.2 cm
- Tube Tank:
height x width x depth:
39.4 cm x 18.7 cm x 46.7 cm
- SID (focus to II surface distance): 993 mm
- Focus to end of collimator assembly distance: 14.8 cm (source to diaphragm distance); 20.3 cm (source to IEC 20 cm spacer cover); 30.3 cm (source to HHS 30 cm spacer cover)

FD 21 x 21 cm

- Flat Detector:
height x width x depth:
10.6 cm x 32.5 cm x 32.5 cm
- Tube Tank:
height x width x depth:
39.4 cm x 18.7 cm x 46.7 cm
- SID (focus to II surface distance): 993 mm
- Focus to end of collimator assembly distance: 14.8 cm (source to diaphragm distance); 20.3 cm (source to IEC 20 cm spacer cover); 30.3 cm (source to HHS 30 cm spacer cover)

Mobile View Station

- Monitors:
height x width x depth:
37.3 cm x 42.4 cm x 10 cm
- Find drawings on next page

- Monitors:
height x width x depth:
37.3 cm x 42.4 cm x 10 cm
- Find drawings on next page

- Monitors:
height x width x depth:
37.3 cm x 42.4 cm x 10 cm
- Find drawings on next page

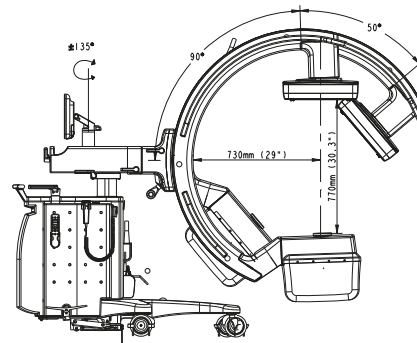
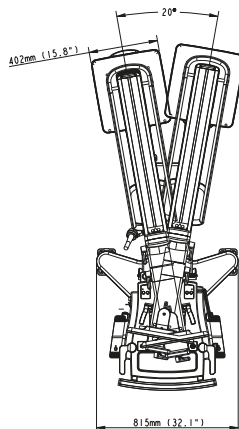
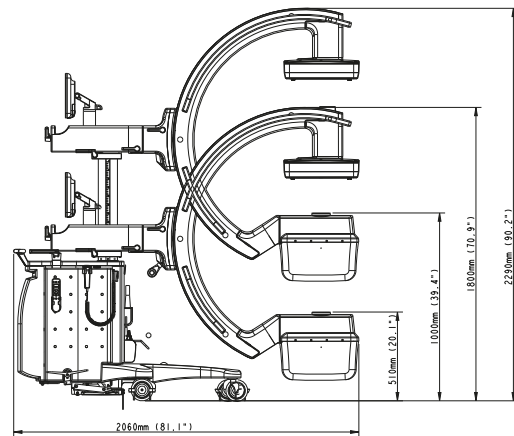
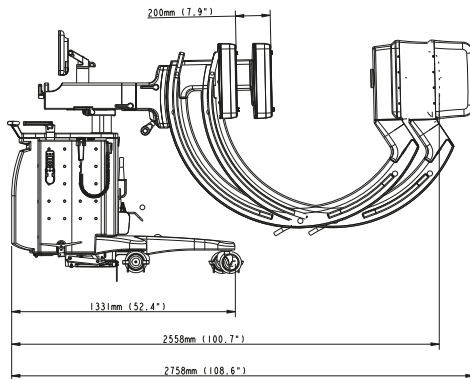

Zenith 70 with 30 x 30 cm flat detector

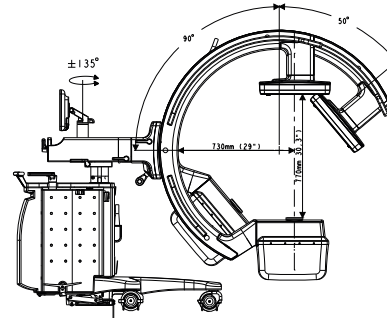
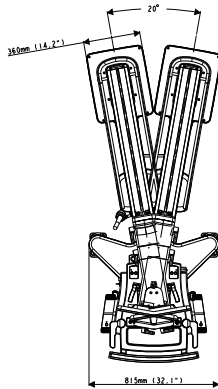
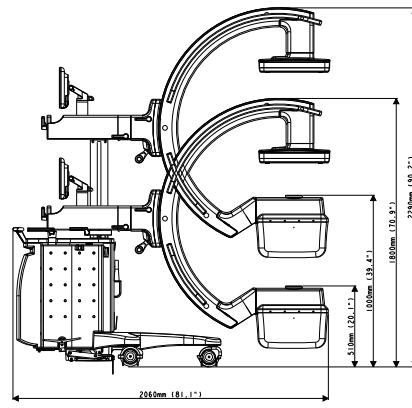
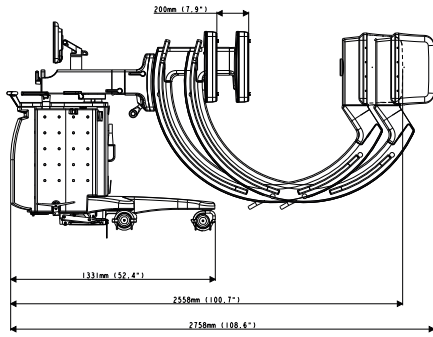

Zenith 70 with 26 x 26 cm flat detector

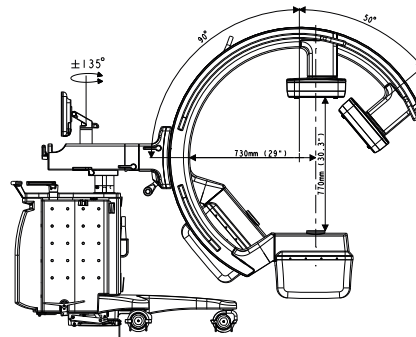
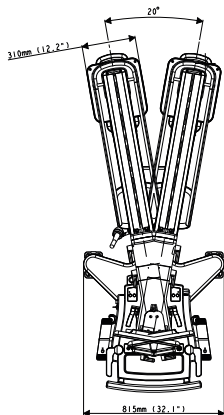
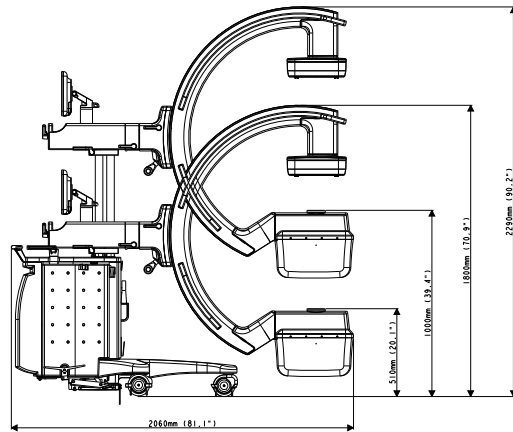
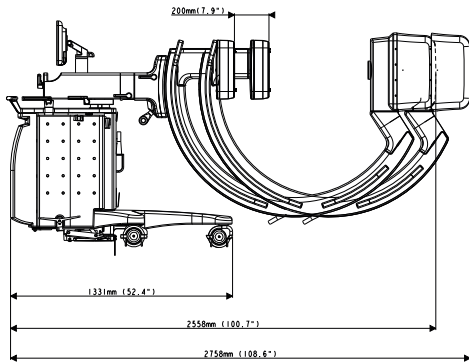

Zenith 70 with 21 x 21 cm flat detector

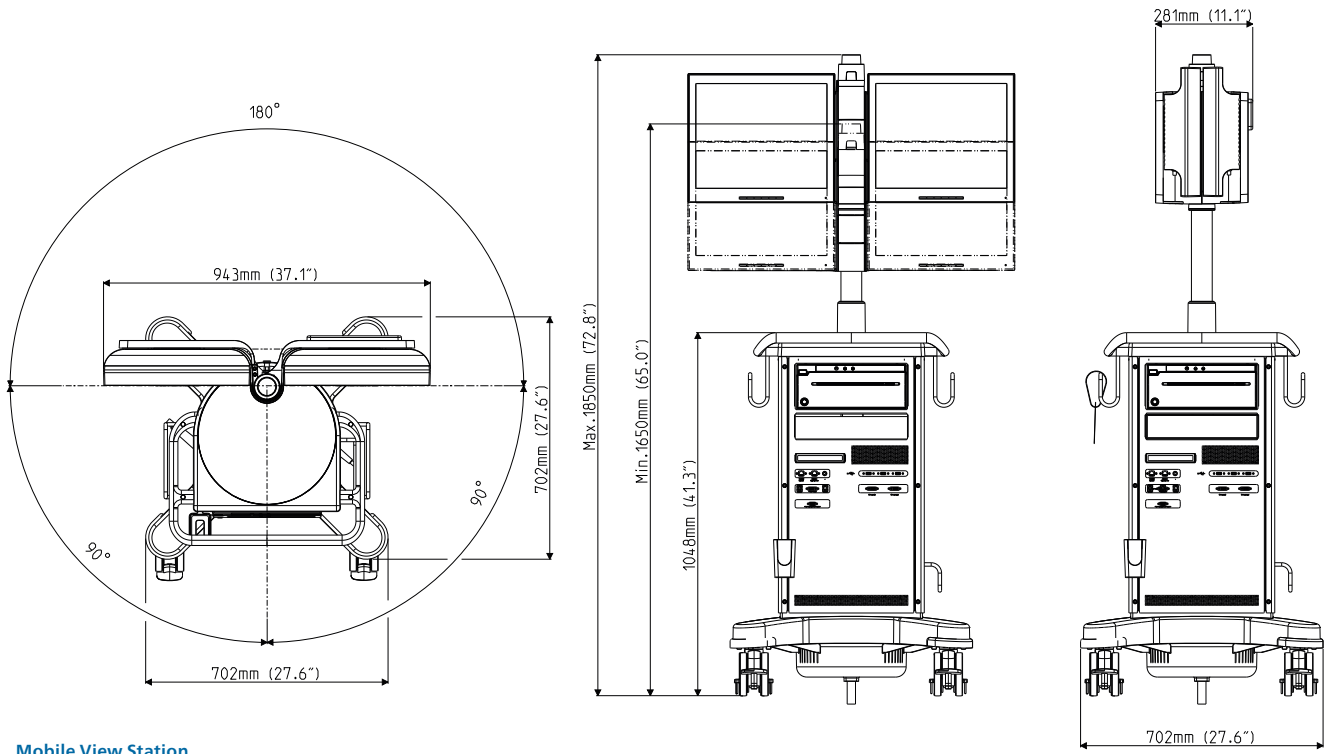

Mobile View Station

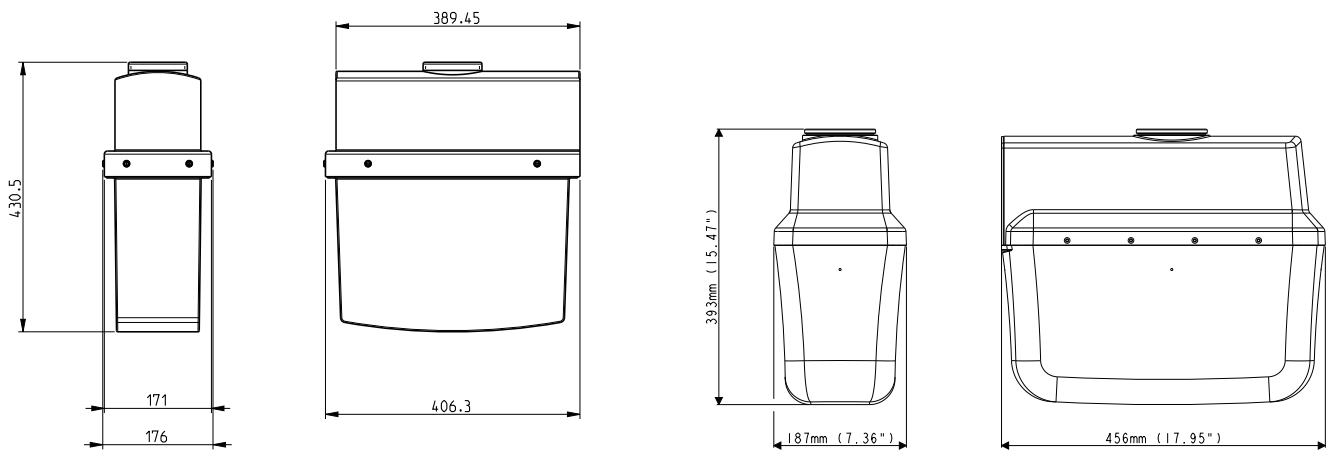

Tube tank, old

Tube tank, new

9 - Options

Specifications

Position tracking and position memory	With Position Memory, you can store up to four positions (angulation, rotation, horizontal position and C-arm height) and recall them later on the screen when needed to speed up re-positioning. The system displays both the current position and the saved position on the C-arm stand monitor which guides the operator back to the exact projection required. Also it is possible to recall the position of every stored image.
Tank laser aiming device (in addition to standard laser on flat detector)	Optional laser projects a crosshair from the X-ray tank towards the Flat Detector, indicating the center of the X-ray beam and enabling alignment of the C-arm without X-ray.
Video paper printer	Thermal printer to print video images from the live (left) monitor on to paper during or after examinations. Print 1, 2, 4, or 6 images on one page in landscape or portrait format. Sony UP-97xAD printer.
Video paper/transparency printer	Thermal printer to print video images from the live (left) monitor on to paper or transparencies during or after examinations. Print 1, 2, 4, or 6 images on one page in landscape or portrait format. Sony UP-99xAD printer.
DICOM and IHE	Zenition 70 can be equipped with the Philips Integrated DICOM solution, which transfers images from the Zenition 70 onto the hospital network in a Secondary Capture DICOM SC or a DICOM XA format. The Basic DICOM package supports DICOM Print and DICOM Store. The advanced DICOM/IHE package (optional) supports: <ul style="list-style-type: none"> • Modality Worklist Management • Modality Performed Procedure Step • Storage Commit • Full compliance to the IHE Scheduled Workflow integration profile as an Acquisition Modality Actor • Query/Retrieve (Image Viewer option)
Image Viewer	Offers an intuitive multi-purpose platform for retrieving and handling DICOM images from different modalities. It lets you compare pre-operative images side-by-side with the live fluoroscopy images. 500 Gbyte hard disk. <ul style="list-style-type: none"> • MIP / MPR - maximum intensity projection singles out high intensity areas for optimized 2D projection of a 3D volume
Wireless data transfer	The Wireless Data Transfer option allows users to connect to the RIS / HIS to send and retrieve images or other relevant data wirelessly and reduce the amount of cable clutter in the OR.

Specifications

Handheld remote control

The remote control unit is a handheld infrared keypad used to control the main image handling functions. For sterile operation, it can be used in a transparent sterile plastic cover. The functions include:

- Run loop
- Overview run / exam
- Retrieve previous image / run
- Retrieve next image / run
- Park image on Reference monitor
- Retrieve image from Reference monitor (Smart mask)
- Protect image / release image
- Mode selection
- Detector-format selection
- Subtraction on / off
- Image grab

Footswitch

Wired footswitch cable length: 3.5 m and Wireless



Handheld remote control and handswitch



Wired footswitch



Wireless footswitch

10 - Options

Specifications

RightFit Customer Service Agreement	Different RightFit Customer Service Agreements are available that allow you to leverage the capabilities of your in-house service teams to maintain and service your Zenition 70 system to reduce delays and improve uptime.
Technology Maximizer	A program that runs in tandem with your RightFit Customer Service Agreement. ¹ When you opt into the program, you receive the latest available software and hardware technology releases for a predictable fee.
Planning	<ul style="list-style-type: none"> • System installation project management • Room design services
Start-up	<ul style="list-style-type: none"> • Clinical application education • In-house service training • Online learning center
Peak usage	<ul style="list-style-type: none"> • Comprehensive, partner and flexible service agreements • Remote services • Service information portal
Renewal	<ul style="list-style-type: none"> • Installed base programs • System relocation services • Refurbished systems
Remote proactive support	One valuable feature in our Service Agreements is remote support. It helps you get the most from your imaging system and maintain its peak performance every day. Philips Remote Services is an advanced, secure network that links your Zenition 70 to our global remote services customer care centers. Configuration, customization, log file analysis and other services that formerly required on-site visits are now available by connecting to our remote experts. Remote system log analysis allows our experts to detect anomalies and plan an on-site visit to increase efficiency. Remote service helps to maintain equipment performance – protecting you against lengthy downtime and unexpected costs. If a deteriorating situation is detected by our remote service, corrective action can be carried out quickly and decisively, often with no interruption to your busy schedule. Our application specialist can also use the remote viewing feature to resolve application-related issues more quickly, without an on-site visit. A global platform for system communication certifies that all service data is handled via best-in-class encrypted transmission technology.

¹ Eligible RightFit Service Agreements are available with Technology Maximizer.





Not all products are available in all geographies. Please reach out to your Philips representative for products and services in your area

© 2022 Koninklijke Philips N.V. All rights reserved. Specifications are subject to change without notice. Trademarks are the property of Koninklijke Philips N.V. or their respective owners.

4522 991 74891 * FEB 2022

How to reach us
Please visit www.philips.com
healthcare@philips.com