

Dedicated to Delivery
Nasco **Life/form**®

**Complete CRiSis™ Torso
Manikin
LF03957U
Instruction Manual**



ISO 9001 and
ISO 13485

Nasco Plastics
ISO 9001 and ISO 13485

Products are manufactured using a quality management system
certified as being in conformity with ISO 9001 and ISO 13485.

Life/form®



Life/form® Products by Nasco **Warranty**

Life/form® CRISIS™ Manikins by Nasco

All models can be upgraded with modular components

	Catalog Number	Airway Management: Digital, Oral, & Nasal Intubation**	Bifurcated Trachea & Stomach	Blood Pressure Arm	CPR	Defibrillation Pacing Capable	ECG Arrhythmia Simulator	Electronic Monitoring, Memory, & Printer	Femoral Access	Heart & Lung Sounds	Intraosseous Infusion	IV/Injection Arm	Jaw Thrust	Tongue Edema & Laryngospasm
Adult Full-Bodied CRISIS™ Manikins*														
"Airway Larry" Airway Management Trainer without Electronic Connections	LF03671U	✓	✓		✓								✓	
"Airway Larry" Airway Management Trainer with Electronic Connections	LF03672U	✓	✓		✓								✓	
Complete CRISIS™ Manikin	LF03953U	✓		✓	✓	✓						✓		
Complete CRISIS™ Manikin with Advanced Airway Management	LF03952U	✓	✓	✓	✓	✓						✓	✓	✓
Deluxe CRISIS™ Manikin	LF03955U	✓	✓	✓	✓	✓	✓					✓	✓	✓
Deluxe CRISIS™ Manikin with Interactive ECG Simulator and Advanced Airway Management	LF03987U	✓	✓	✓	✓	✓	✓					✓	✓	✓
Deluxe Plus CRISIS™ Manikin	LF03956U	✓	✓	✓	✓	✓	✓					✓	✓	✓
Deluxe Plus CRISIS™ Manikin with Interactive ECG, CPR Monitoring, and Advanced Airway Management	LF03988U	✓	✓	✓	✓	✓	✓					✓	✓	✓
Adult Full-Bodied CRISIS™ Manikins with Heart & Lung Sounds*														
Complete CRISIS™ Auscultation Manikin with Advanced Airway Management	LF03986U	✓	✓	✓	✓	✓						✓	✓	✓
Complete CRISIS™ Auscultation Manikin	LF03965U	✓	✓	✓	✓	✓						✓	✓	✓
Complete CRISIS™ Auscultation Manikin with ECG Simulator	LF03966U	✓	✓	✓	✓	✓	✓					✓	✓	✓
Deluxe CRISIS™ Auscultation Manikin with Advanced Airway Management	LF03984U	✓	✓	✓	✓	✓	✓					✓	✓	✓
Deluxe Plus CRISIS™ Auscultation Manikin	LF03968U	✓	✓	✓	✓	✓	✓					✓	✓	✓
Deluxe Plus CRISIS™ Auscultation Manikin with Advanced Airway Management	LF03985U	✓	✓	✓	✓	✓	✓					✓	✓	✓
Adult CRISIS™ Torso*														
CRISIS™ Torso Manikin	LF03957U	✓	✓		✓	✓							✓	
CRISIS™ Torso Manikin with Advanced Airway Management	LF03982U	✓	✓		✓	✓							✓	✓
Deluxe CRISIS™ Torso Manikin	LF03958U	✓	✓	✓	✓	✓							✓	✓
Deluxe CRISIS™ Torso Manikin with Advanced Airway Management	LF03983U	✓	✓	✓	✓	✓	✓						✓	✓
Advanced "Airway Larry" Airway Management Torso with Defibrillation	LF03960U	✓	✓		✓	✓	✓						✓	✓
Advanced "Airway Larry" Airway Management Trainer Torso	LF03686U	✓	✓	✓	✓	✓							✓	✓
"Airway Larry" Airway Management Trainer Torso	LF03669U	✓	✓	✓	✓	✓							✓	✓

✓ = Included with model

**ET, EOA, PTL, LMA, EGTA, Combitube®, and King® Systems (use only on adult and child) insertion

***Excludes Nasal Intubation



The Complete **CRiSis**™ Torso Manikin is a complete resuscitation system consisting of modular components that allow you to create a manikin to suit your changing needs. The components may be purchased as a complete package or separately to update your existing manikin. Update packages are compatible with all versions of **CPARLENE**®.

This manual will guide you in setting up, using, and maintaining each of the available components. Also included is a list of replacement parts, supplies, and auxiliary equipment.

By reading and following all instructions carefully and completely, you can be sure your **Life/form**® Complete **CRiSis**™ Torso Manikin will provide years of valuable service.

List of Components

- Complete **CRiSis**™ Torso Manikin
- 8-oz. Pump Spray Lubricant (LF03644U)
- Short Sleeve Jacket
- Red Caps (3)

About the Simulator

Features:

- **Airway Management**
 - Anatomically correct nostrils, teeth, tongue, oral and nasal pharynx, larynx, cricoid ring, epiglottis, arytenoid, false and true vocal cords, trachea, and esophagus.
 - Practice oral, digital, and nasal intubation.
 - Intubate with E.T., E.O.A., P.T.L., Combitube®, and King System.
 - Practice suction and proper cuff inflation.
 - Visible chest rise or stomach inflation.
- **CPR**
 - Adult compression depth
 - Visible chest rise
 - Mouth to Mouth or BVM compatible
- **Defibrillation Chest Skin**
- **Interactive ECG capabilities**



Figure 1

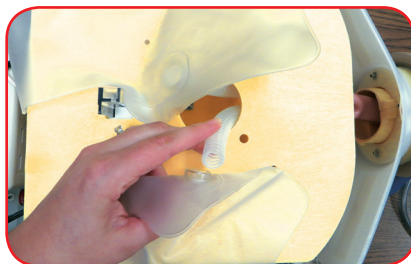

Figure 3



Figure 2



Figure 4

Set Up

A. Installing the Chest Compression Springs

1. Remove the chest skin, chest plate, and upper compression plate.
Note: Caution must be taken not to damage the defibrillation electronics attached to the chest skin.
2. Remove the compression springs from packaging. Insert the springs into the four plastic cylinders extending up from the lower compression plate. (See figure 1.)
3. Position the upper compression plate over the springs so that each of the springs fits up into a cylinder on the bottom of the upper compression plate. (See figure 2.)

B. Connecting the Airway

1. The manikin's airway has been disconnected to prevent damage during shipping.
 2. With the chest skin and chest plate still removed feed the corrugated bronchial tubes up through the hole in the center of the upper compression plate and connect to the back of the lung bags. (See figure 3.)
 3. Place the chest plate back over the upper compression plate and lungs.
 4. Reattach the chest skin by adjusting the hook-and-loop edges. Again, be careful not to damage the electronics attached to the chest skin.
- Note:** The chest skin should not be drawn too tightly over the torso as it could restrict compression retraction or appropriate chest rise during ventilation.

C. Pulse Feature

The Airway Management Trainer Head is equipped with squeeze bulb for activating a manual carotid pulse. (See figure 4.)



Figure 5



Figure 6



Figure 7

D. Stomach Feature

Connected to the esophagus, the **CRiSis™** Torso Manikin is equipped with a stomach intended only as an indicator of improper intubation (stomach rise). **(See figure 5 & inset.)**

E. Lubricating the Airway Trainer Head

Lubricate both the simulator and supplies being used with the pump spray lubricant provided. **(See figures 6 & 7.)**(Endotracheal Tube sold separately.)

Note: Nasco recommends the use of the provided lubricant or a similar vegetable-based lubricant for the Airway Management Trainer Head. The use of a silicone-based lubricant may cause damage to the simulator, thus voiding Nasco's warranty on the trainer.

General Instructions for Use

A. Intubating the Complete CRiSis™ Torso Manikin

Nasco recommends the use of a 7.5-8 mm endotracheal tube for oral intubation and 7.5 cm or smaller for nasal intubation. This simulator allows for the Sellick's Maneuver of applying cricoid pressure during intubation procedures. Ensuring the cuff is properly deflated prior to removal will prolong the useful life of your simulator. Damage caused by improper use of the simulator will not be covered under the warranty.

1. Determine the method of intubation.
2. Select the appropriate sized intubation appliance.
3. Generously lubricate the airway and appliance.
4. Intubate the manikin.
5. Visualize chest rise or stomach inflation.
6. Ensure the cuff is properly deflated before removing the appliance.

Note: Remove all appliances prior to storage.

B. Using a Combitube (Not Included)

Thoroughly read and follow the instructions that come with the combitube. The trainer will accept either a full size or a small adult tube. As with a real patient, it may be necessary to back the tube out if ventilation cannot be established.

Note: Depending on tube placement, the large cuff may not accept the recommended amount of air. In this case, simply inflate the cuff to its maximum volume (when the plunger stops) and while holding the plunger down, detach the syringe from the blue print balloon and proceed.

C. Defibrillating the Manikin

Defibrillating with Paddles or Gel Pads

1. Defibrillate the manikin by placing paddles or gel pads on the round, metal defibrillation sites on the manikin's chest. (**See diagram 1.**) As with a real patient extreme care should be taken to make complete contact with the sternum and apex defibrillation site.

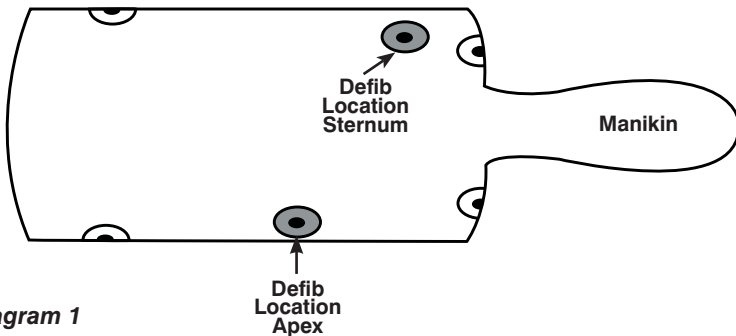

Diagram 1

2. The equipment is now ready for defibrillation practice. Follow all normal safety precautions indicated for use and training.



Figure 8



Figure 9



Figure 10



Figure 11

Note: In an effort to help you save money, Nasco offers sets of defibrillation training cables and chest post adapters, sold separately, to be used in place of defibrillator paddles or gel pads. Nasco does not sell defibrillators or monitors.

Defibrillating with Snap-on Cables

Adapter posts, sold separately, are available to fit a variety of defibrillator brands' snap-on cable heads. Be sure to identify your brand of defibrillator before selecting an adapter post set. (See the Supplies and Replacement Parts section of this manual for more information.)

1. Feed the banana clip through the protective disc and screw the adapter post specific to your snap-on cable head to the banana clip. **(See figures 8 & 9.)**
2. Insert the banana clip end into the manikin's chest skin defibrillation location and snap the cable to the adapter post. **(See figures 10 & 11.)**

Note: Cables must be placed in the appropriate defibrillation location, sternum or apex.

3. The equipment is now ready for defibrillation practice. Follow all normal safety precautions indicated for use and training.

Defibrillating with Training Cables

Training cables purchased from Nasco have snap-on heads assembled with the standard Training Cable Defib Adapter Post shown. Brand specific adapter posts are only needed if you are using your own snap-on defib cables with unique heads. Nasco training cables have unique plug-ins for use with your own defibrillator's specific brand. Custom training cables can be made for brands not seen below; contact Nasco for information. **IMPORTANT:** Training cables are NOT recommended for use with battery operated AED's with non-rechargeable lithium batteries.



Zoll Training Cable with Assembled Training Cable Adapter Posts, LF03961U



Physio Control Training Cable with Assembled Training Cable Adapter Posts, LF03962U

1. Insert the cable plug into your defibrillator.
2. Insert the banana clip end into the manikin defibrillation location.
3. The equipment is now ready for defibrillation practice. Follow all normal safety precautions indicated for use and training.

Note: The simulator can accept a maximum energy level of 360 joules. Nasco recommends administering the lowest possible shock in order to extend the life of your simulator.

D. Connecting Your Manikin to an Arrhythmia Simulator, or Life/form® Interactive ECG Simulator (LF03670U) and Defib/Monitor (Sold Separately)

Nasco has designed the **CRiSis™** line of manikins to be compatible with a variety of arrhythmia simulators and suggests the use of the **Life/form®** Interactive ECG Simulator – LF03670U (sold separately).



- **ON/OFF** – Press to power on and off.
- **LOW BAT** – Red indicator illuminates when battery needs replacement.
- **DEFIB DISCHG** – Green indicator illuminates for two seconds when defib discharge is sensed. **If defibrillating Nasco manikin, set defib to 2J or more. If defibrillating directly into ECG Simulator, set defib to 50J or more.**
- **convert** – Simulate cardioversion by activating convert feature. Simulator responds to defib discharge.
- **Adult Ped** – Yellow indicators tell which rhythm set is being simulated – adult or pediatric.
- **age group** – Press to select adult or pediatric rhythm set.
- **PACER PULSE** – Green indicator flashes when external pacer pulse is sensed. (Captured beat is simulated too.) Sensing occurs when external pacer current set to 60mA – 70mA or more.

1. Snap the colored ends of the four-lead cable coming from the manikin to the appropriate locations on the ECG Simulator. (See **Figure 12.**)

Figure 12

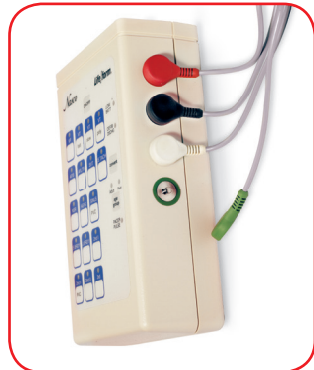

2. Connect your defibrillator's colored limb-lead snaps to the appropriate locations on the manikin's chest skin. (See **diagram 2.**)

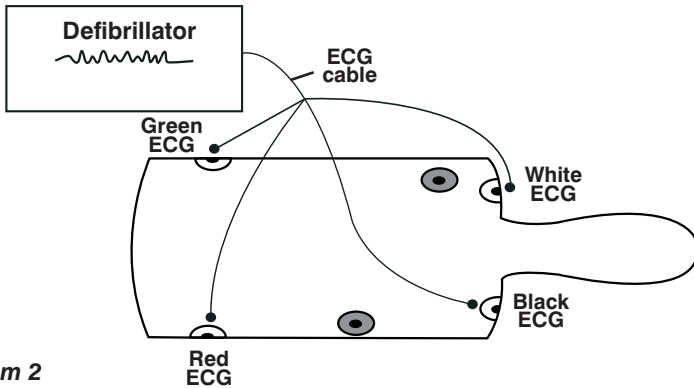

Diagram 2

3. You should now be able to select rhythms on the ECG Simulator and view them on your monitor.
4. Change rhythm selected from waiting rhythm to running rhythm automatically using the Convert button and applying a shock to the manikin.

Note: The running rhythm indicator light is solid while the waiting rhythm blinks on and off. After the shock is applied to the manikin, the blinking rhythm indicator light turns solid and the original solid light turns off.
5. Apply paddles, gel pads, defibrillator cables with adapter posts, or training cables to the appropriate defibrillation location on the manikin. **(See diagram 3.)**

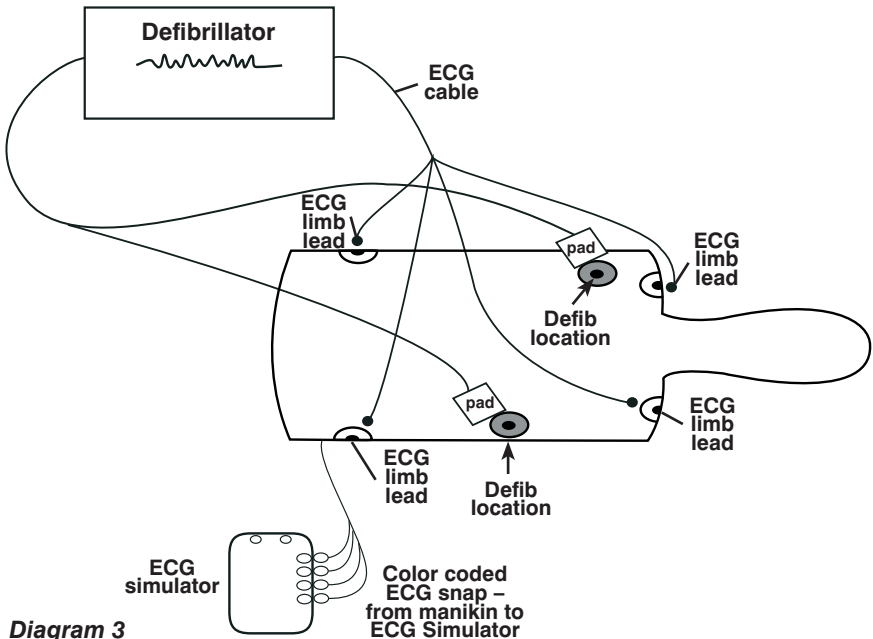

Diagram 3

6. To change the age group select the age group key, then the rhythm you wish to select. **Note:** At Power On the adult age group is automatically selected.

Adult Defibrillation Training

- VF** Ventricular Fibrillation
- VT fast** Ventricular Tachycardia. Wide QRS. Rate: 185
- VT slow** Ventricular Tachycardia. Wide QRS. Rate: 140
- VT poly** Ventricular Tachycardia. Fluctuating QRS axis.
- AFIB** Atrial Fibrillation. Ventricular rate: 120-160
- AFLTR** Atrial Flutter (2:1). Ventricular rate: 150
- SVT** SVT alternates with NSR, then remains in SVT. SVT rate: 216
- S TACH** Sinus Tachycardia. Rate: 120
- NSR** Normal Sinus Rhythm. Rate: 72
- ASYS** Asystole
- SINUS PVC** Sinus Rhythm with PVCs. Sinus rate: 72

Adult External Pacer Training

- S BRDY** Sinus Bradycardia. Rate: 40
- J BRDY** Junctional Bradycardia. Rate: 42
- 2nd I** 2nd deg. type I AV Block (4:3). Atrial rate: 60
- 2nd II PVC** 2nd deg. type II AV Block (4:3). PVCs. Wide QRS. Atrial rate: 60
- 2nd II** 2nd deg. type II AV Block (4:3). Wide QRS. Atrial rate: 60
- 3rd** 3rd deg. AV Block. Wide QRS. Ventricular rate: 37

Pediatric Defibrillation Training

- VF** Ventricular Fibrillation
- VT fast** Ventricular Tachycardia. Wide QRS. Visible P wave, Rate: 180
- VT slow** Ventricular Tachycardia. Wide QRS. Rate: 148
- VT poly** Ventricular Tachycardia. Fluctuating QRS axis. Short runs.
- AFIB** Atrial Fibrillation. Small R waves. Ventricular rate: 135-160
- AFLTR** Atrial Flutter (2:1). Ventricular rate: 150
- SVT** Supraventricular Tachycardia. Inverted P follows QRS. rate: 216
- S TACH** Sinus Tachycardia. Rate: 165
- NSR** Normal Sinus Rhythm. Rate: 90
- ASYS** Asystole
- SINUS PVC** Sinus Rhythm with PVCs. Sinus rate: 90

Pediatric External Pacer Training

- S BRDY** Sinus Bradycardia. Rate: 50
- J BRDY** Junctional Bradycardia. Rate: 60
- 2nd I** 2nd deg. type I AV Block (5:4). Atrial rate: 60
- 2nd II PVC** 2nd deg. type II AV Block (5:4) with PVCs. Atrial rate: 60
- 2nd II** 2nd deg. type II AV Block (5:4). Atrial rate: 60
- 3rd** 3rd deg. AV Block. Ventricular rate: 60

Care and Maintenance

A. General Cleaning

Normal surface soil can be removed from the trainer with mild soapy water. Do not allow water to contact electrical components. Stubborn stains may be removed with Nasco Cleaner (LF09919U). Simply apply the Nasco Cleaner to the soiled area and wipe clean with a soft cloth.

Note: Avoid using cleaner around the mouth area if students will be applying direct mouth-to-mouth resuscitation techniques, as the cleaner may be toxic if ingested.



Figure 13

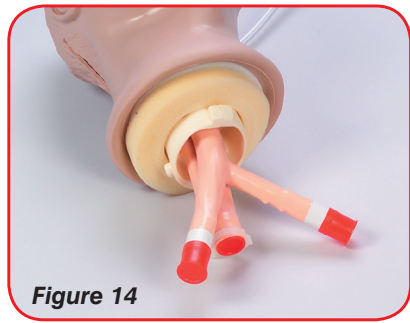

Figure 14

B. Cleaning the Airway Management Trainer Head

1. Remove the chest skin and chest plate.
2. Disconnect the lungs from the bronchi and esophagus from the tubing to the stomach. Then, rotate the head so that it is facing backwards. The large tab on the front of the neck should be aligned with the keyway in the torso. Tilt the head upward until it snaps free. Disengage the smaller rear tabs from the neck opening and pull the head from the body. (**See figure 13.**) Reverse these steps to reattach the head.
3. Take the trainer to an area with a sink and open counter space. Using the red caps supplied, plug off the right and left bronchi and the esophagus.
4. Stabilize the head on the counter face-up (towels work well for this) with plugged tubes hanging over the sink. (**See figure 14.**)
5. Carefully pour warm soapy water (a mild dish soap works best) into the mouth until the water level reaches halfway up the tongue.
6. Tilt the head back and bring the neck up 3" off the countertop.
7. Continue filling until the water level covers the tongue. Take a small soft brush and gently scrub the inside of the mouth (a small tooth brush works well for this). Cotton swabs can be used to scrub inside the nostrils.
8. When done, pull the plug from the esophagus and drain the water into the sink.

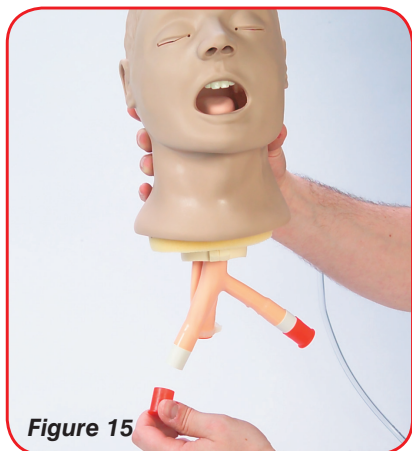

Figure 15

9. Now pick the head up, hold it in a vertical position, and pull the plugs from the bronchi to completely empty the system. (See figure 15.)
10. Rinse the airway, following the same procedure used to clean, with warm tap water only. Repeat this process until all the soap has been flushed from the system.

C. Disinfecting the Airway

To disinfect, repeat the standard cleaning procedure, with a bleach solution, as specified by the Centers for Disease Control.

1. Fill the system with the solution until it reaches the corners of the mouth. Remember to start filling with the head flat and finish with the neck slightly elevated to ensure that the solution completely fills all airway passages.
2. Once completely filled with the bleach solution, allow the head to sit for at least 10 minutes.
3. Drain as previously described earlier and repeat the rinsing process to flush out all of the bleach solution. Set the head aside and allow it to air dry completely prior to next use or storage.

D. Storage

Retain the padded shipping container to store your clean, dry simulator between uses.

To Store for an Extended Period:

1. Remove any intubation appliance used.
2. Remove the chest skin and chest plate.
3. Disconnect the airway from the lungs pushing the corrugated bronchial tubes through the hole in the center of the upper compression plate.
4. Remove the upper compression plate.
5. Remove the compression springs from the four plastic cylinders in the lower compression plate.
6. Loosely wind the ECG cable and place in the base of the torso, near the load box.

7. Replace the upper compression plate over the four plastic cylinders in the lower compression plate.
8. Place the Chest Plate over the upper compression plate.
9. Replace the chest skin and jacket.
10. Cover the simulator with a clear, plastic trash liner.
11. Place the clean, dry simulator in the retained padded shipping container.

Cautions

- Do not place simulator in contact with any printed paper or plastic. The ink will transfer and cause an indelible stain. Similar inks, such as ball-point pen will also cause an indelible stain.
- Do not use Nasco Cleaner (LF09919U) around the nose or mouth of the simulator. The cleaner may be toxic if ingested.
- Properly lubricate the Airway Management head and intubation appliances.
- Use only Nasco Pump Spray lubricant (LF03644U) with this simulator. Other lubricants such as silicone oil may cause damage to the airway of the simulator.
- Ensure intubation appliances are used accordingly. Improper use of intubation appliances could damage the airway of the simulator. Damage to the airway will require the product to be returned to Nasco for repair.
- Do not exceed a maximum energy level of 360 joules during defibrillation practice.

Troubleshooting

Problem ECG wave is not being picked up from the manikin.

Solution

1. Check your connections on the patient simulators; one or more may be disconnected.
2. Check to make sure your patient simulator is plugged in and working properly.

Problem ECG wave is inverted.

Solution

Recheck the position of the red and black lead snaps on the patient simulator.

Note: If the defibrillation skin is not functioning or wiring comes undone, please contact us to repair or replace the unit. Failure to do so, or unauthorized repair, may void the warranty or cause further harm or damage to your equipment.

Supplies/Replacement Parts

- LF03285U** Replacement Lung Set
- LF03628U** Replacement Stomach
- LF03644U** 8 oz. Pump Spray Lubricant
- LF03656U** Physio Control Adapter Posts for LifePak 10 and LifePak 20
- LF03657U** Marquette Adapters Posts
- LF03658U** SpaceLabs/Laerdal/Heartstart/First Medic Adapter Posts
- LF03670U** **Life/form**® Interactive ECG Simulator
- LF03670BU** Adapter Posts Set (SpaceLabs/Laerdal/Heartstart/First Medic, Marquette, Physio Control, and Training Cable Adapter Posts with Banana Clips and Protective Discs.)
- LF03961U** Zoll Training Cables with Adapter Posts and Protective Discs. (Image on Page 8)
- LF03962U** Physio Control Training Cables with Adapters Posts and Protective Discs. (Image on Page 8)
- SB32214U** Physio Control — Training Cable Only
- SB32215U** Zoll — Training Cable Only
- SB46514U** Phillips — Training Cable Only

Note: If you need help selecting the training cables or adapter posts that correspond to your AED unit, please feel free to call us at **1-800-558-9595** or e-mail: lifeform@eNasco.com for assistance.

Actual product may vary slightly from photo. Nasco reserves the right to change product color, materials, supplies, or function as needed.



Other Available *Life/form*® Simulators

- LF03000U** **CPARLENE**® Series
LF03601U Adult Airway Management Trainer with Stand
LF03602U Adult Airway Management Manikin
LF03609U Child Airway Management Trainer with Stand
LF03616U Child **CRiSis**™ Manikin
LF03617U Deluxe Child **CRiSis**™ Manikin with Arrhythmia Tutor
LF03620U PALS Update Kit
LF03623U Infant Airway Management Trainer with Stand
LF03632U Child Intraosseous Infusion/ Femoral Access Leg on a Stand
LF03633U Child Airway Management Trainer Torso
LF03693U **Basic Buddy**® CPR Manikin
LF03699U "Airway Larry" Airway Management Trainer
LF03709U Infant **CRiSis**™ Manikin
- LF03720U** **Baby Buddy**™ Infant CPR Manikin
LF03750U Bariatric CPR Manikin
LF03760U Airway Management/Cricoid Pressure Trainer
LF03770U Chest Tube
LF03953U **CRiSis**™ Manikin, Complete
LF03955U Deluxe **CRiSis**™ Manikin
LF03956U Deluxe "Plus" **CRiSis**™ Manikin
LF03965U Adult **CRiSis**™ Auscultation Manikin
LF03966U Adult **CRiSis**™ Auscultation Manikin with ECG Simulator
LF04200U Adult Sternal Intraosseous Infusion
LF06001U CPR Prompt® Adult/Child Manikin
LF06012U CPR Prompt® Infant Manikin
LF06200U CPR Prompt® Keychain Rescue Aid
LF06204U CPR Prompt® Rescue and Practice Aid



LF03214U



LF03204U

LF03840U



Nasco Fort Atkinson

901 Janesville Avenue, P.O. Box 901
 Fort Atkinson, Wisconsin 53538-0901
 1.800.558.9595

eNasco.com • E-mail: lifeform@eNasco.com